



# WEET Technology Company Limited

## Single Phase Bridge Rectifiers

**DB201 THRU DB207**

**REVERSE VOLTAGE - 50 to 1000Volts**  
**FORWARD CURRENT - 2.0 Amperes**

**FEATURES**

- Rating to 1000V PRV
- Ideal for printed circuit board
- Low forward voltage drop, high current capability
- Reliable low cost construction utilizing molded plastic technique results in inexpensive product
- Lead tin Pb/Sn copper
- The plastic material has UL flammability classification 94V-0

**MECHANICAL DATA**

- Polarity: As marked on Body
- Weight: 0.02 ounces, 0.38 grams
- Mounting position: Any

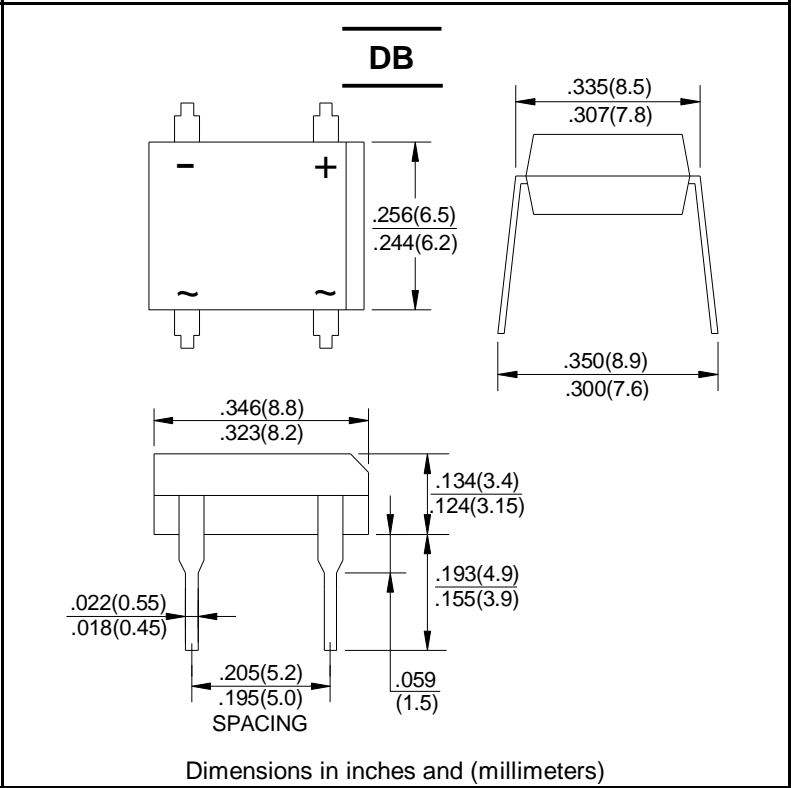

**MAXIMUM RATINGS AND ELECTRICAL CHARACTERISTICS**

Rating at 25°C ambient temperature unless otherwise specified.  
 Single phase, half wave, 60Hz, resistive or inductive load.  
 For capacitive load, derate current by 20%

| CHARACTERISTICS  | SYMBOL            | DB201       | DB202 | DB203 | DB204 | DB205 | DB206 | DB207 | UNIT             |
|--|-------------------|-------------|-------|-------|-------|-------|-------|-------|------------------|
| Maximum Recurrent Peak Reverse Voltage   | V <sub>RRM</sub>  | 50          | 100   | 200   | 400   | 600   | 800   | 1000  | V                |
| Maximum RMS Voltage  | V <sub>RMS</sub>  | 35          | 70    | 140   | 280   | 420   | 560   | 700   | V                |
| Maximum DC Blocking Voltage  | V <sub>DC</sub>   | 50          | 100   | 200   | 400   | 600   | 800   | 1000  | V                |
| Maximum Average Forward Rectified Current @ T <sub>A</sub> =40°C                                       | I <sub>(AV)</sub> | 2.0         |       |       |       |       |       |       | A                |
| Peak Forward Surge Current 8.3ms Single Half Sine-Wave Super Imposed on Rated Load (JEDEC .Method)     | I <sub>FSM</sub>  | 60          |       |       |       |       |       |       | A                |
| Maximum Forward Voltage at 2.0A DC   | V <sub>F</sub>    | 1.1         |       |       |       |       |       |       | V                |
| Maximum DC Reverse Current @ T <sub>J</sub> =25°C at Rated DC Blocking Voltage @ T <sub>J</sub> =125°C | I <sub>R</sub>    | 10          |       |       |       |       |       |       | uA               |
| I <sup>2</sup> t Rating for Fusing (t<8.3ms)   | I <sup>2</sup> t  | 10.4        |       |       |       |       |       |       | A <sup>2</sup> s |
| Typical Junction capacitance Per Element(Note1)  | C <sub>J</sub>    | 25          |       |       |       |       |       |       | pF               |
| Typical Thermal Resistance (Note2)   | R <sub>θJC</sub>  | 40          |       |       |       |       |       |       | °C/W             |
| Operating Temperature Range  | T <sub>J</sub>    | -55 to +150 |       |       |       |       |       |       | °C               |
| Storage Temperature Range  | T <sub>STG</sub>  | -55 to +150 |       |       |       |       |       |       | °C               |

Note:1.Measured at 1.0MHz and applied reverse voltage of 4.0V DC  
 2.Thermal resistance from junction to ambient mounted on P.C.B with 0.5\*0.5"(13\*13mm) copper pads.



# WEET Technology Company Limited

## Single Phase Bridge Rectifiers

### RATING AND CHARACTERISTIC CURVES

FIG.1-DERATING CURVE FOR OUTPUT RECTIFIED CURRENT

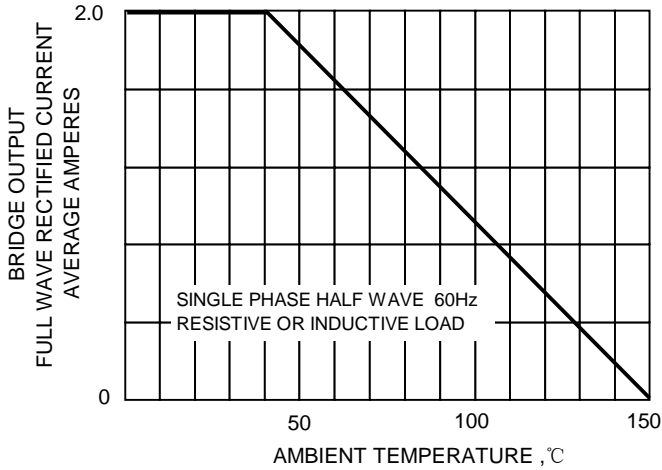

FIG.2-MAXIMUM NON-REPETITIVE PEAK FORWARD SURGE CURRENT

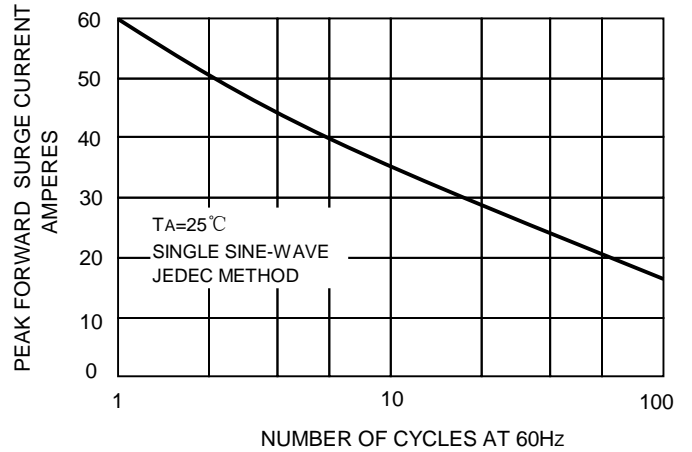

FIG.3-TYPICAL JUNCTION CAPACITANCE

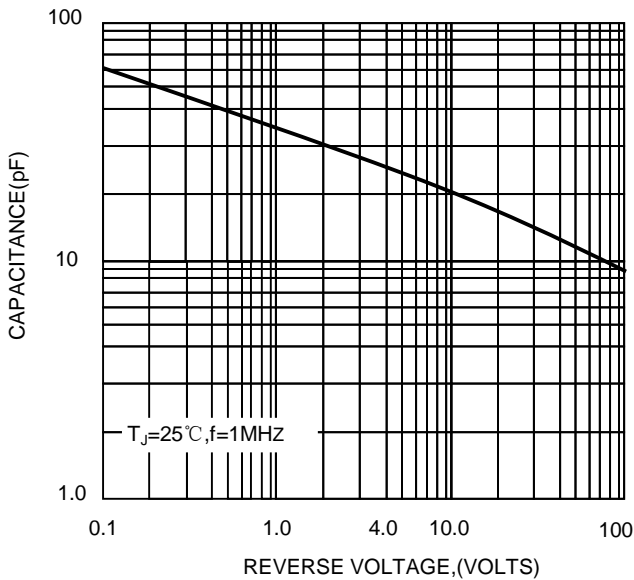

FIG.4-TYPICAL FORWARD CHARACTERISTICS

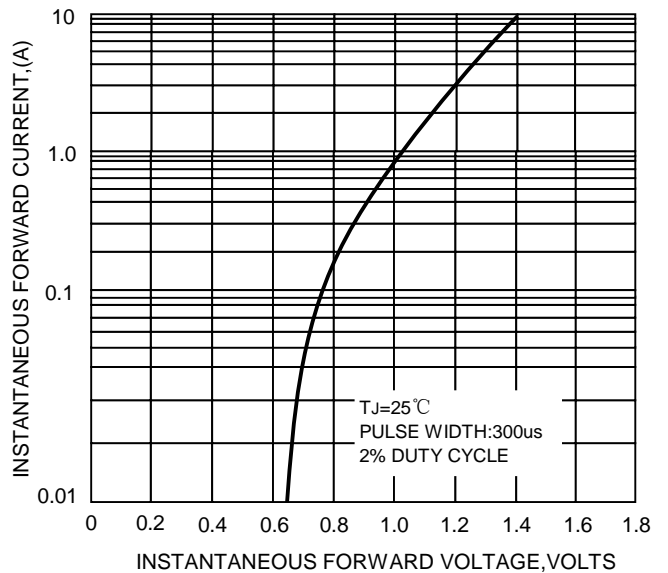
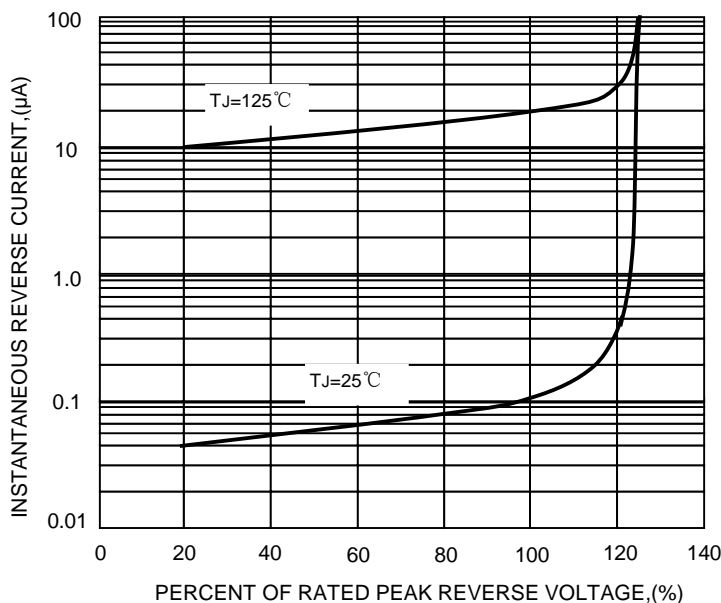

FIG.5-TYPICAL REVERSE CHARACTERISTICS



Note: Specifications are subject to change without notice. For more detail and update, please visit our website.