



WEET Technology Company Limited

Schottky Barrier Rectifiers

1N5820 THRU 1N5822

VOLTAGE RANGE 20 to 40 Volts
CURRENT 3.0 Ampere

FEATURES

- Low switching noise
- Low forward voltage drop
- High forward surge capability
- High reliability
- High temperature soldering guaranteed
260°C/10 seconds, 0.375" (9.5mm) lead length at 5 lbs (2.3kg) tension

MECHANICAL DATA

- Case: Transfer molded plastic
- Epoxy: UL94V-0 rate flame retardant
- Polarity: Color band denotes cathode end
- Lead: Plated axial lead, solderable per MIL-STD-202E method 208C
- Mounting position: Any
- Weight: 0.012ounce, 0.33 grams

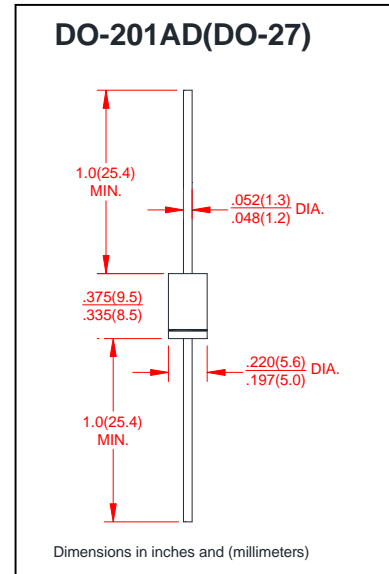

MAXIMUM RATINGS AND ELECTRICAL CHARACTERISTICS

- Ratings at 25°C ambient temperature unless otherwise specified
- Single Phase, half wave, 60Hz, resistive or inductive load
- For capacitive load derate current by 20%

	SYMBOLS	1N5820	1N5821	1N5822	UNITS
Maximum Repetitive Peak Reverse Voltage	V_{RRM}	20	30	40	Volts
Maximum RMS Voltage	V_{RMS}	14	21	28	Volts
Maximum DC Blocking Voltage	V_{DC}	20	30	40	Volts
Maximum Average Forward Rectified Current 0.375" (9.5mm) lead length at $T_L=95^\circ\text{C}$	$I_{(AV)}$	3.0			Amps
Peak Forward Surge Current 8.3mS single half sine-wave superimposed on rated load (JEDEC method)	I_{FSM}	80			Amps
Maximum Instantaneous Forward Voltage at 3.0A	V_F	0.475	0.500	0.525	Volts
Maximum Instantaneous Forward Voltage at 9.4A		0.850	0.900	0.950	Volts
Maximum DC Reverse Current at Rated DC Blocking Voltage	I_R	$T_A = 25^\circ\text{C}$			mA
		$T_A = 100^\circ\text{C}$			
Typical Junction Capacitance (NOTE 1)	C_J	250			pF
Typical Thermal Resistance(Note2)	$R_{\theta JA}$	28			$^\circ\text{C}/\text{W}$
Operating and Storage Temperature Range	T_J, T_{STG}	-55 to +125			$^\circ\text{C}$

Notes:

1. Measured at 1.0MHz and applied reverse voltage of 4.0 Volts.
2. Thermal Resistance Junction to Ambient



WEET Technology Company Limited

Schottky Barrier Rectifiers

1N5820 THRU 1N5822

VOLTAGE RANGE 20 to 40 Volts
CURRENT 3.0 Ampere

FIG.1-TYPICAL FORWARD CURRENT DERATING CURVE

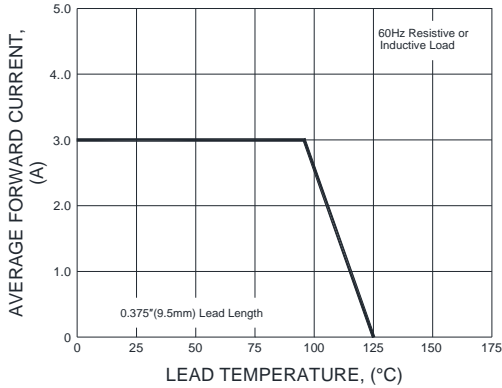

FIG.2-MAXIMUM NON-REPETITIVE PEAK FORWARD SURGE CURRENT

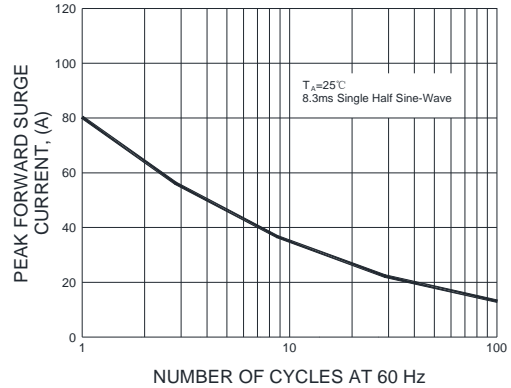

FIG.3-TYPICAL INSTANTANEOUS FORWARD CHARACTERISTICS

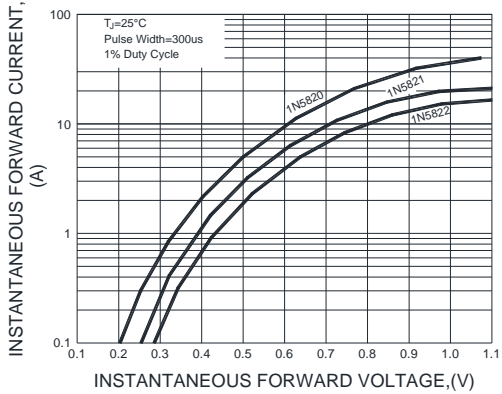

FIG.4-TYPICAL REVERSE CHARACTERISTICS

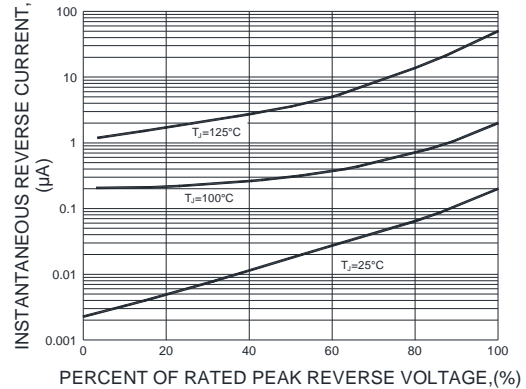
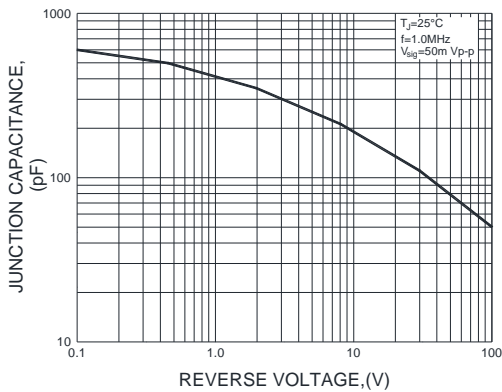

FIG.5-TYPICAL JUNCTION CAPACITANCE



Note: Specifications are subject to change without notice. For more detail and update, please visit our website.